

Product: **KLUDI L-INE single lever sink mixer DN 10**

Ref.: **428540577**

### Product description

single lever sink mixer DN 10  
 solid lever  
 two hole mounted  
 flow class Z  
 PCA Cache aerator M 16,5 x l  
 ceramic cartridge with hot water safety device  
 swivel spout (360°)  
 rapid installation set  
 flexible high pressure supply tubes G 3/8  
 noise group I

Finishes:  
 05 chrome

### Product picture



### Advertisement

- \* KLUDI GmbH & Co KG KLUDI L-INE 2 - hole sink mixer item no. 428540577
- \*\* chrome plated brass, DIN EN 50930-6
- \*\*\* ceramic cartridge with hot water safety device Ø 35 mm, DIN EN 817

2 - hole sink mixer, manufacturer KLUDI GmbH & Co. KG KLUDI L-INE 2 - hole sink mixer item no. 428540577, DN 10, chrome plated brass, type: 2 - hole sink mixer DN 10, swivel spout, solid lever, lever projection 85 mm, PCA Cache aerator M 16,5 x l, noise level DIN EN 4109 group I, flow level Z, nozzle projection 210 mm, rapid installation set, flexible high pressure supply tubes 3/8 inch with DVGW / KIWA / WRAS / CSTB approval with metal body length 400 mm, nozzle height 280 mm, ceramic cartridge with hot water safety device Ø 35 mm, overall length 321 mm, for pressure type water heater, for continuous line heater, PN 10,

### Dimensional drawing

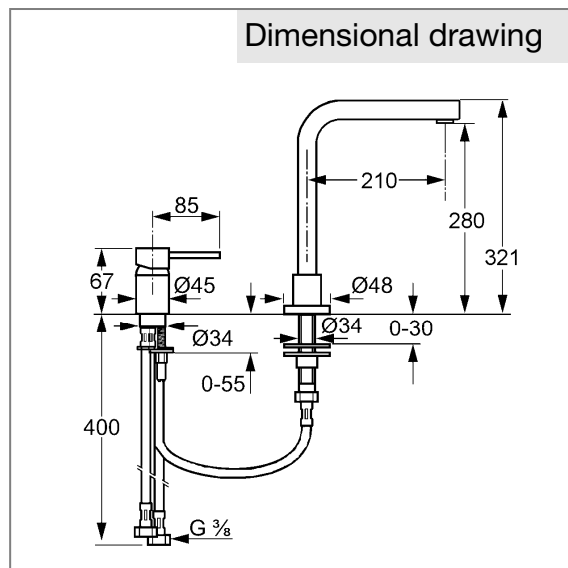

### Flow rate diagram

